

Rasen-Roboter Elektronik Pin Belegung der Arduino Mega 2560

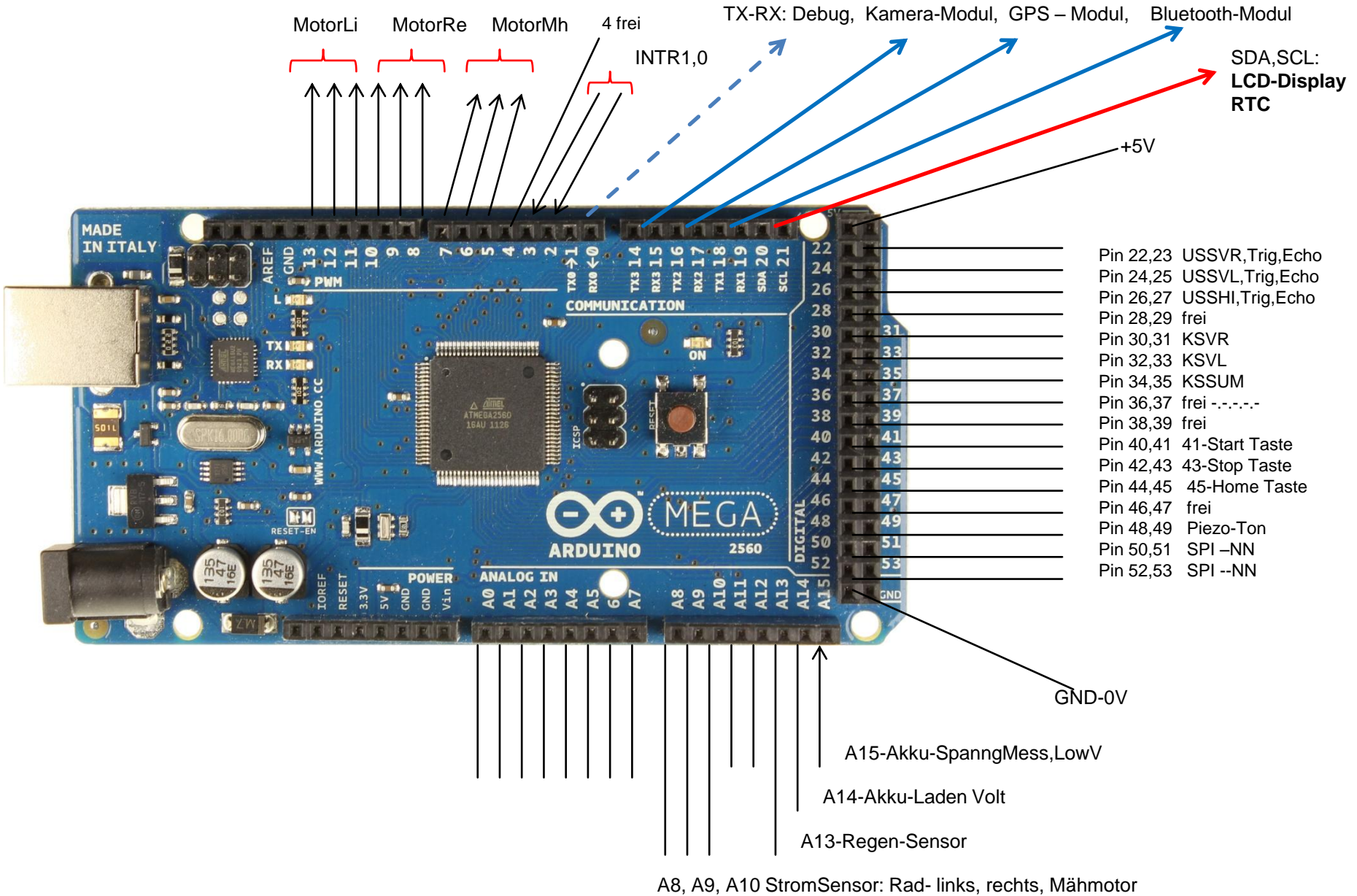

Rasen-Roboter Elektronik Pin Belegung der Arduino DUE - 3,3 V Input / Output

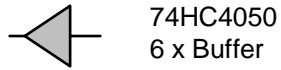

4050 : Buffer & TTL Driver (Non-Inverting)

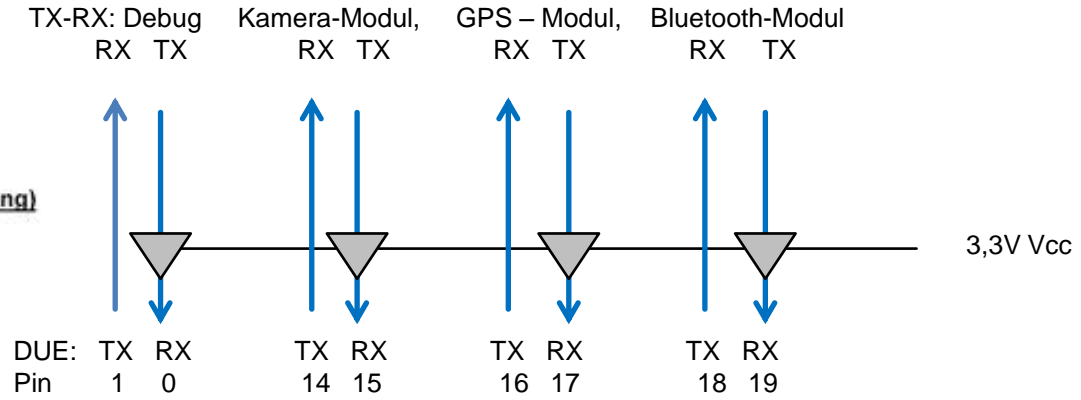
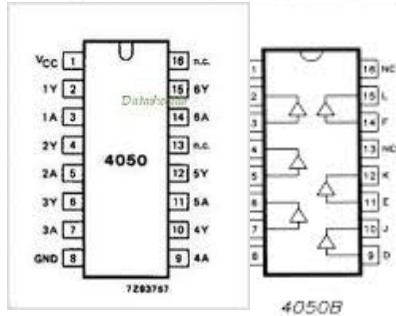

LCD-Display
RTC
IMU - 9DOF

SDA SCL

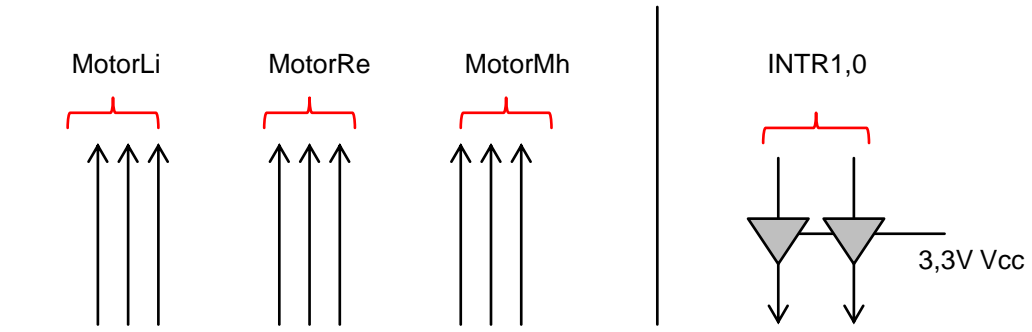

DUE: Motor -Links PWM IN1, IN2, -Rechts, MähMotor, Pin4 Frei, Pin 3, 2

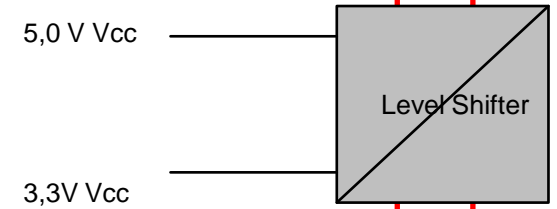

DUE: SDA SCL Pin 20 21

Rasen-Roboter Elektronik Pin Belegung der Arduino DUE - 3,3 V Input / Output

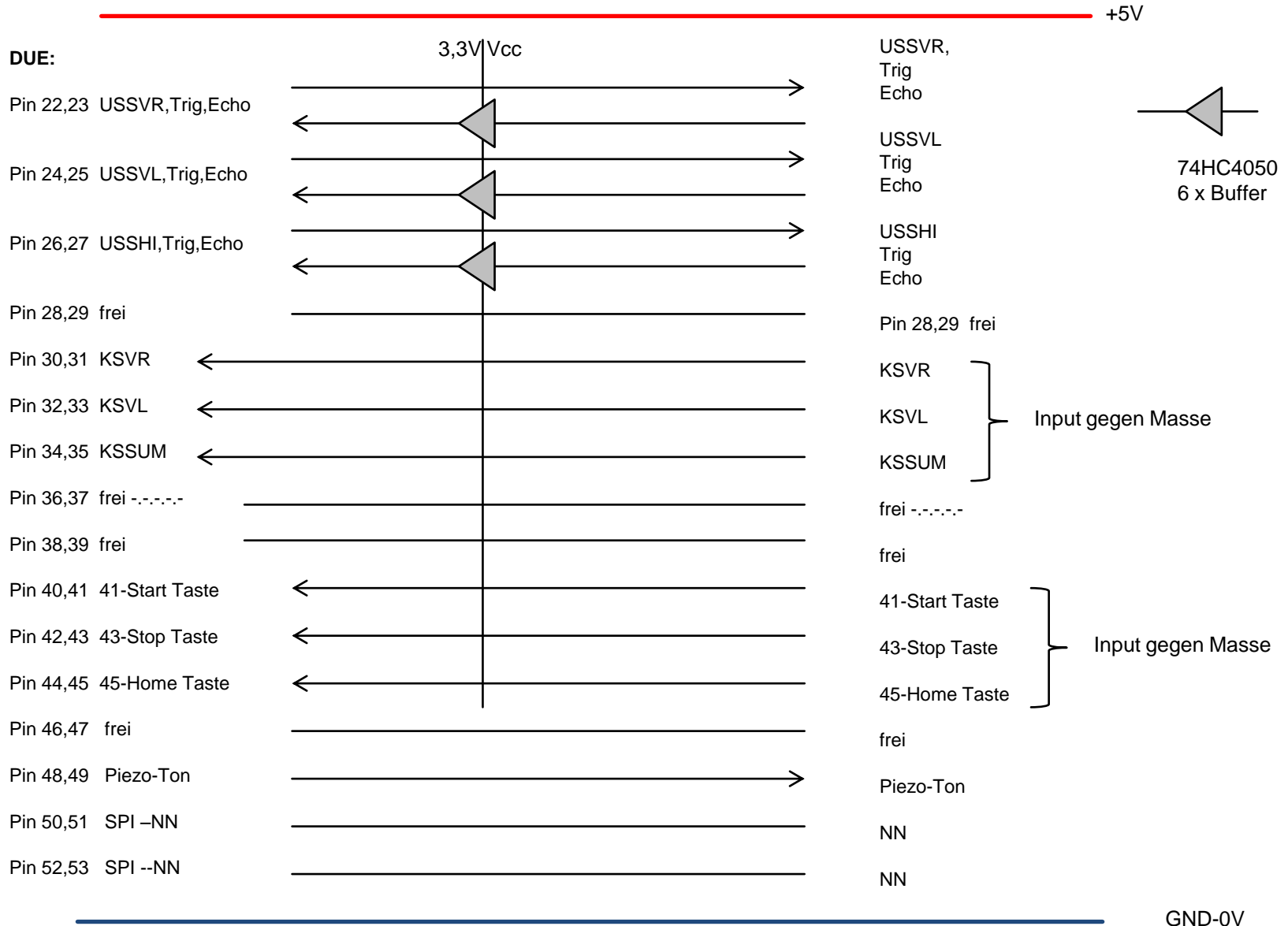

Rasen-Roboter Elektronik Pin Belegung der Arduino DUE - 3,3 V Analog Input

