

1 2 3 4 5 6

A
B

A
B

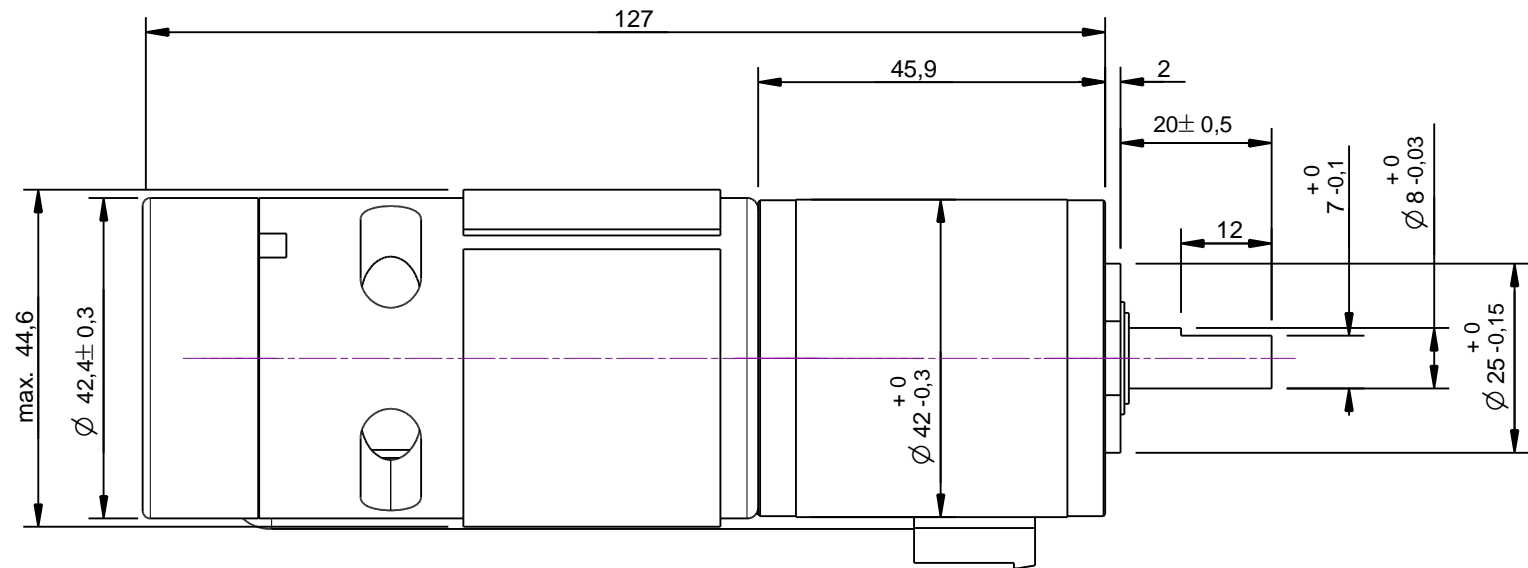
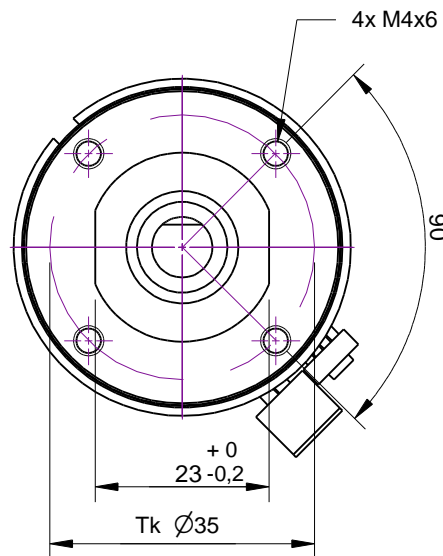

C

C

Motordaten :
 Nennspannung : 24 V
 Nenndrehmoment : 2,5 Nm
 Nenndrehzahl : 31 rpm
 Übersetzung : 1:212

Ausgangsbeschaltung	Zwei Kanal Encoder 2 x 5 Imp.
<p>5mA < I_{cc} < 10 mA</p>	schwarz : -Motor
	rot : +Motor
	braun : Hall Sensor Vcc 3,5 - 20 V
	grün : Hall Sensor GND
	blau : Hall Sensor A Vout
	Violett : Hall Sensor B Vout

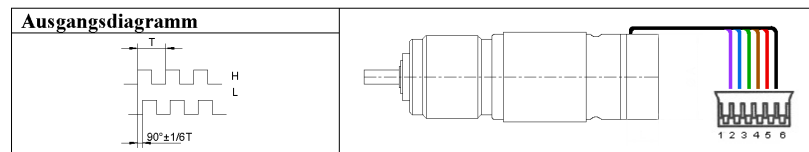

D

D

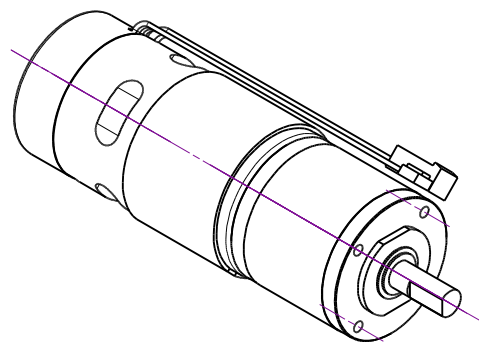

URHEBERSCHUTZ NACH DIN 34

Zust.	Änderung	Datum	Name
2014	Datum		Name
Bearb.	27.03.		Kornberger
Gepr.	27.03.2014		Ma.Ott



Ott GmbH & Co.KG
 D-78652 Deißlingen
 Tel.:0049-07420-93990

Maßstab	
Werkstoff / Rohteil	
Benennung	DC Planetengetriebemotor 24 V ,Hall.IC 2x14 Imp.
Zg.Nr.	XDP045010-03
Blatt	

1 2 3 4 5 6